



DPM INVEST

domy pod miastem

Osiedle Róży

**PARAMETRY
DOMU**

G1

90,6 m²

166,3 m²

**BIURO
SPRZEDAŻY**

607-053-895

kontakt@dpminvest.pl

Aleja Krakowska 30
Janki

PIĘTRO 48,3 m²

Lp. Pomieszczenie Powierzchnia [m²]

4.	Sypialnia	11,4
5.	Łazienka	7,2
6.	Garderoba	2,2
7.	Pom. Gosp.	2,7
8.	Komunikacja	5,1
9.	Pokój1	9,6
10.	Pokój2	10,1

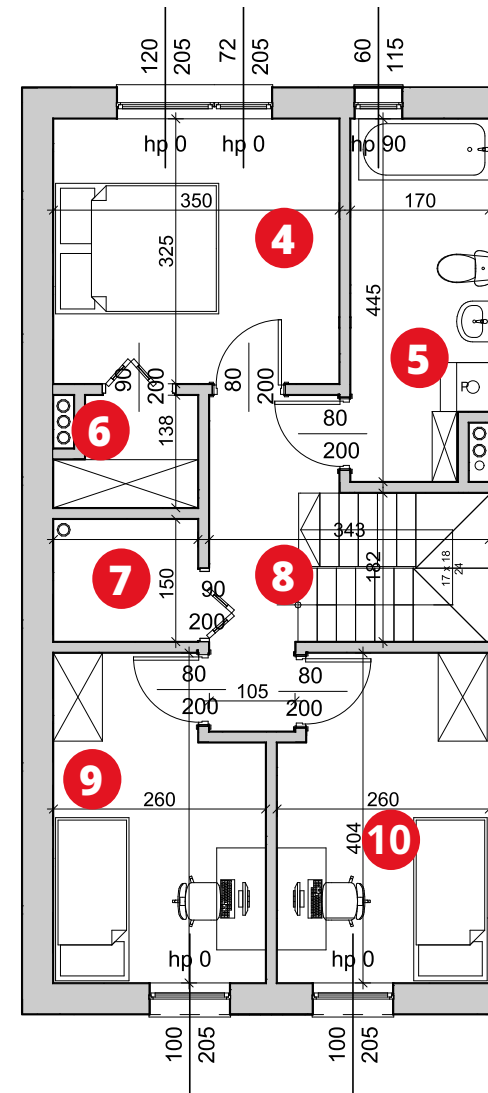
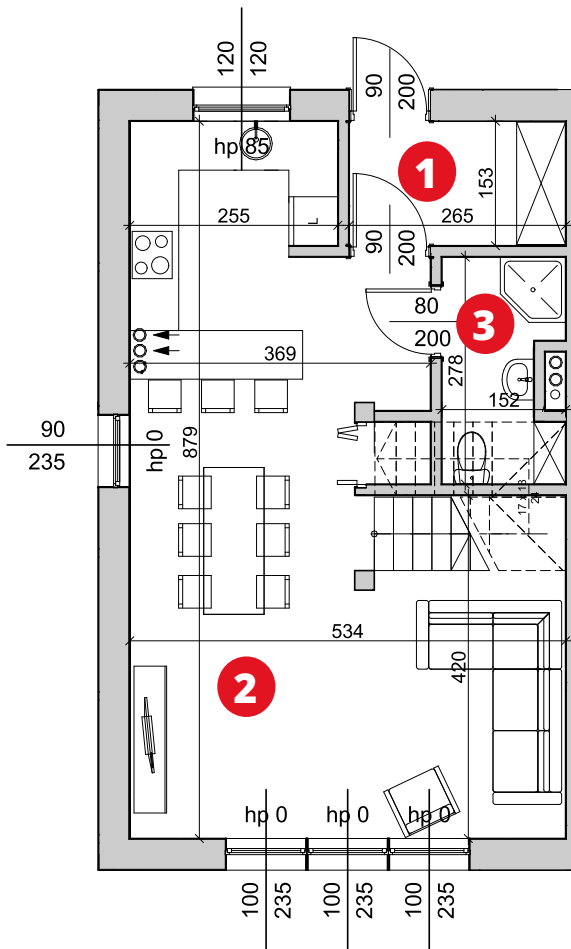

PARTER 42,3 m²

Lp. Pomieszczenie Powierzchnia [m²]

1.	Wiatrołap	4,0
2.	Salon/Kuchnia	35,2
3.	Łazienka	3,1

